

**CURTISS -  
WRIGHT**

# Future Energies

[www.cwst.com](http://www.cwst.com) | [www.cwst.co.uk](http://www.cwst.co.uk)

## COMPANY PROFILE

Curtiss-Wright Corporation (NYSE:CW) is a global integrated business that provides highly engineered products, solutions and services mainly to Aerospace & Defense markets, as well as critical technologies in demanding Commercial Power, Process and Industrial markets.

Our proven surface treatments meet industry demands for lighter materials, improved performance and life extension in key markets such as Aerospace, Automotive, Energy and Medical. We can prevent premature failures due to fatigue, corrosion, wear, galling and fretting.

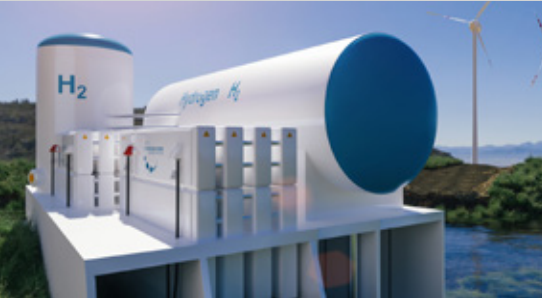

## Future Energies

### Problems We Solve

- More fuel-efficient electric power generation
- More fuel-efficient jet engines
- Greater power-gen efficiency to reduce greenhouse gas emissions
- Help enable new technologies like sCO<sub>2</sub> that have zero greenhouse gas emissions
- Eliminate corrosion cracking in storage of liquid-metals for concentrated solar collectors
- Eliminate stress corrosion cracking in nuclear power generation and spent fuel storage
- Eliminate hydrogen embrittlement for hydrogen storage and use

### Technology We Use to Solve the Problems

- State-of-the-art finite analysis to analytically engineer protective stress into materials.
- Laser and shot peening technology to precisely create the required engineered stresses.
- LP+TME applied to superalloys and HEAs to effect reliable higher temperature operation.
- Laser peening to eliminate corrosion-cracking of liquid metals and concentrated solar collection applications.
- Laser peening to eliminate stress corrosion cracking in nuclear power applications.
- Laser peening to eliminate hydrogen diffusion into metals thereby stopping hydrogen embrittlement failures.

Surface Technologies is a Division of Curtiss-Wright (NYSE:CW) a global innovative company that delivers highly engineered, critical function products and services to the commercial, industrial, defense and energy markets. Building on the heritage of Glenn Curtiss and the Wright brothers, Curtiss-Wright has a long tradition of providing reliable solutions through trusted customer relationships.

**CURTISS -  
WRIGHT**

For more information on all our services and full worldwide contact:

**US: [www.cwst.com](http://www.cwst.com) +1 201.518.2979 | UK: [www.cwst.co.uk](http://www.cwst.co.uk) +44 (0)1635 279621**

## Hydrogen Embrittlement

Hydrogen embrittlement is the process by which metals become brittle and fracture due to the introduction and subsequent diffusion of hydrogen into the metal. Individual hydrogen atoms within the metal gradually recombine, creating pressure that can increase to levels where the metal has reduced ductility, toughness, and tensile strength, to the point where it cracks open.

Computational research (using Parrinello-Rahman molecular dynamics) has shown that instead of leading to a decrease in ductility, there is local enhancement of ductility in areas that are hydrogen saturated. This increase in ductility leads to areas where there is a reduction in the critical tensile stress which leads to failure to occur at lower than expected stresses.

SIMS shows hydrogen content of H<sub>2</sub> charged LP coupon remains comparable to background level

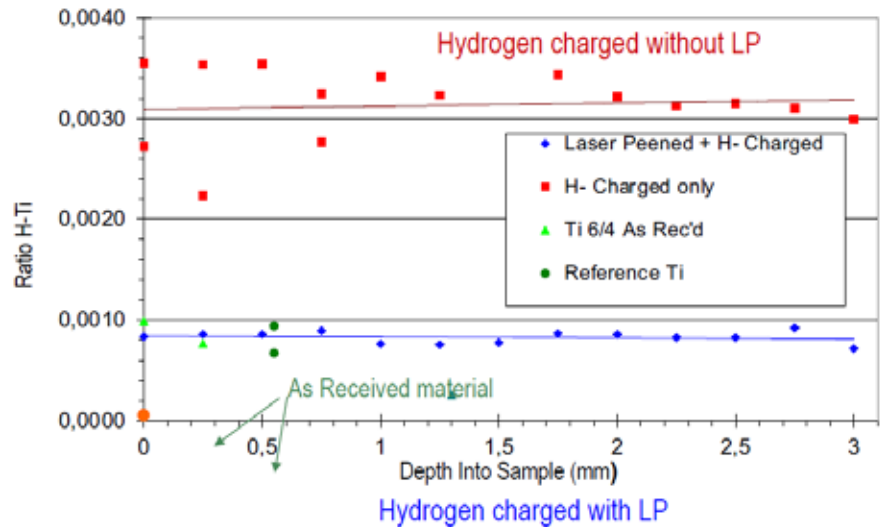

Laser peened with hydrogen charged sample contains 1/3 the hydrogen concentration compared to hydrogen charged sample without laser peening



## Prevent hydrogen embrittlement cracking

Material is an 42CrMo4 with Rm 1700MPa.

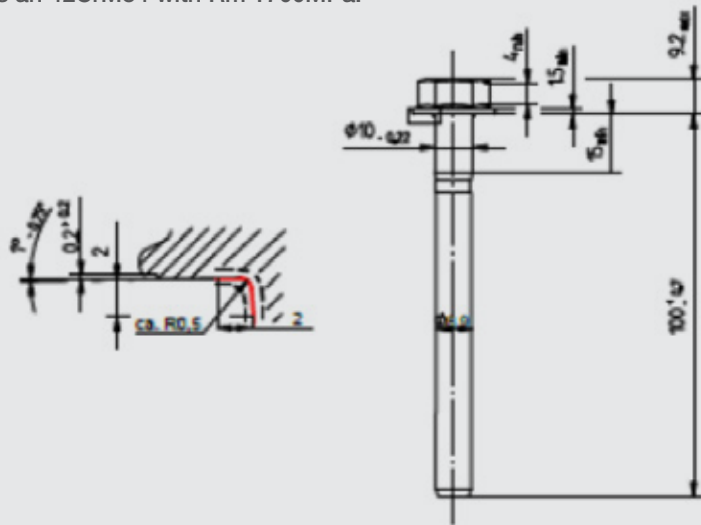

AISI /SAE 4140, DIN 42CrMo4, W.nr. 1.7225, BS 708M42, AFNOR 42CD4, JIS SCM4, SS 2244

For more information on all our services and full worldwide contact:

US: [www.cwst.com](http://www.cwst.com) +1 201.518.2979 | UK: [www.cwst.co.uk](http://www.cwst.co.uk) +44 (0)1635 279621